

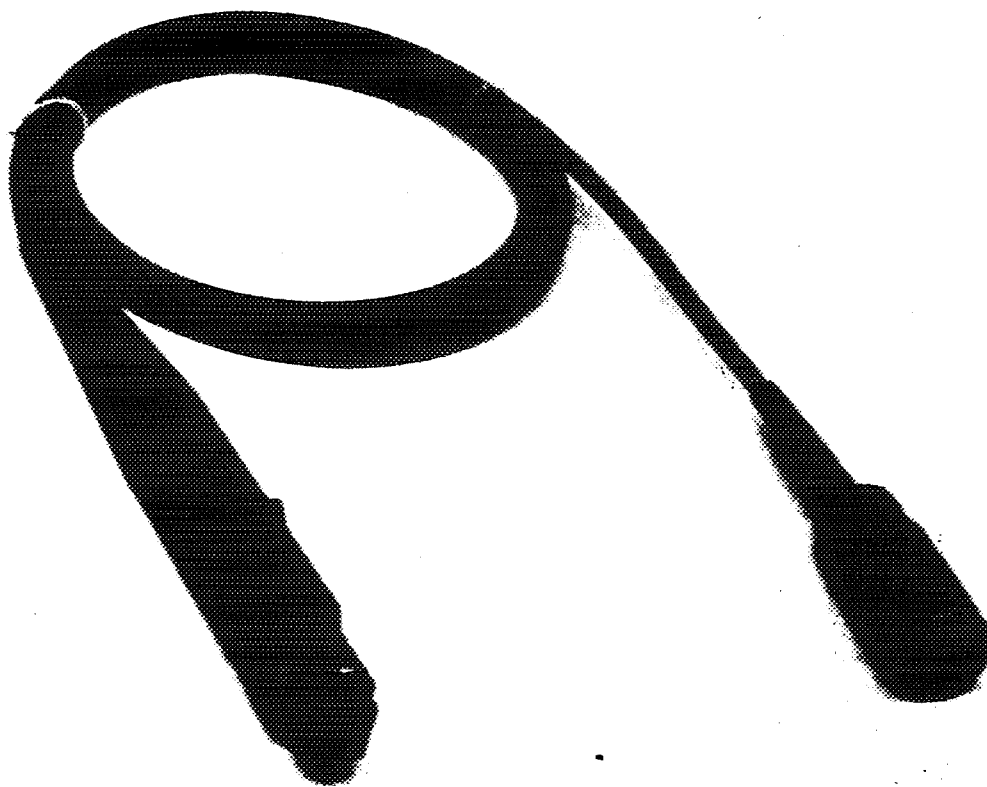

Instructions

P6302

Current Probe



2897-01

WARRANTY

Tektronix warrants to the original purchaser that this product is free from defects in materials and workmanship, under normal use, for a period of one (1) year from the date of shipment. Tektronix will, at its option, repair or replace the product if Tektronix determines it is defective within the warranty period, and it is returned, prepaid, to a Tektronix Service Center.

There is no implied warranty of fitness for a particular purpose. Tektronix is not liable for consequential damages.

Copyright © 1979 by Tektronix, Inc. All rights reserved. Contents of this publication may not be reproduced in any form without the permission of Tektronix, Inc.

Products of Tektronix, Inc. and its subsidiaries are covered by U.S. and foreign patents and/or pending patents.

TEKTRONIX, TEK, SCOPE-MOBILE, and  are registered trademarks of Tektronix, Inc.

Printed in U.S.A. Specification and price change privileges are reserved.

DESCRIPTION

The P6302 is a dc to 50 MHz probe capable of measuring currents to 20 A dc (dc plus peak ac), and up to 50 A peak current, not to exceed the amp-second rating. The P6302 is designed for use with a Current Probe Amplifier.

A Hall generator device is used in the probe to provide dc and low-frequency current information. Low-frequency (from the Hall device) and high-frequency

information (from the current transformer) are combined in the current probe amplifier to produce an accurate representation of the current being measured.

A spring-loaded slider permits the current transformer core to open and close around a conductor. The slider is pushed forward into the CLOSED position to measure the current in a conductor. A multi-pin connector is provided to permit connection of the probe to a current probe amplifier.

SPECIFICATION

The following instrument specification applies over an ambient temperature range of 0°C to +50°C, providing the instruments were calibrated in an ambient

temperature range between +20°C and +30°C. The amplifier and probe must operate for at least 20 minutes before making measurements.

Table 1

ELECTRICAL CHARACTERISTICS

Characteristics	Performance Characteristics	Supplemental Information
Bandwidth	dc to at least 50 MHz	
Risetime	7 ns or less	
Aberrations First 100 ns	+5%, -5%, or less. Total not to exceed 7% p-p; on 100 MHz oscilloscope system	
After 100 ns	+3%, -3%, or less. Total not to exceed 4% p-p; on 100 MHz oscilloscope system	
Noise	≤0.3 mA tangentially measured	Probe Amplifier Bandwidth at 100 MHz, sensitivity 1 mA

P6302 Current Probe

Table 1 (cont)

Characteristics	Performance Characteristics	Supplemental Information
Maximum Input Current dc + peak ac		20 A maximum (ac current not to exceed derating curve for continuous operation); see derating curve, Fig. 1
Peak Pulse		50 A maximum not to exceed Dynamic Range of AM 503
Maximum Voltage on bare conductor being tested		500 V (dc + peak ac)
External Voltage Feedthrough Susceptibility		250 μ A/V or less at 50 MHz

Table 2

ENVIRONMENTAL CHARACTERISTICS

Characteristic	Information
Temperature	
Non-Operating (Storage)	-55°C to +75°C
Operating	0°C to +50°C
Altitude	
Non-Operating	50,000 feet
Operating	15,000 feet

Table 3

PHYSICAL CHARACTERISTICS

Characteristics	Information
Dimensions, Probe Head	
Length	7 7/8 inches
Height	1 1/4 inches
Width	7/16 inch
Jaw Size	0.15 inch

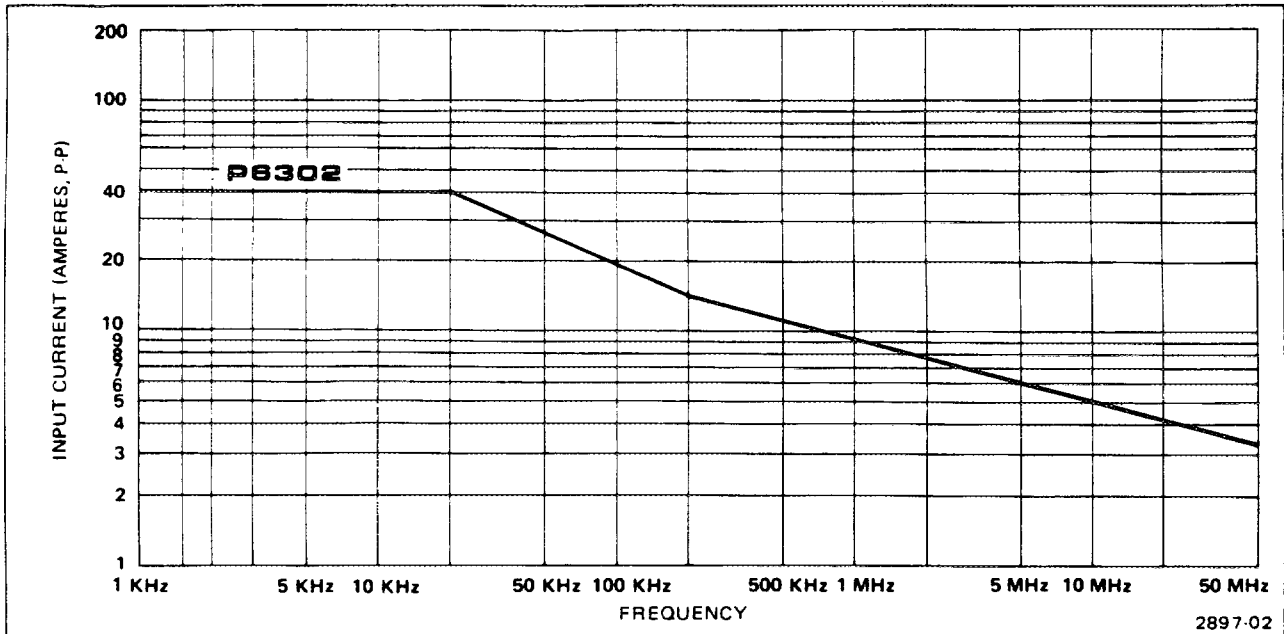

Fig. 1. Maximum input current derating curve.

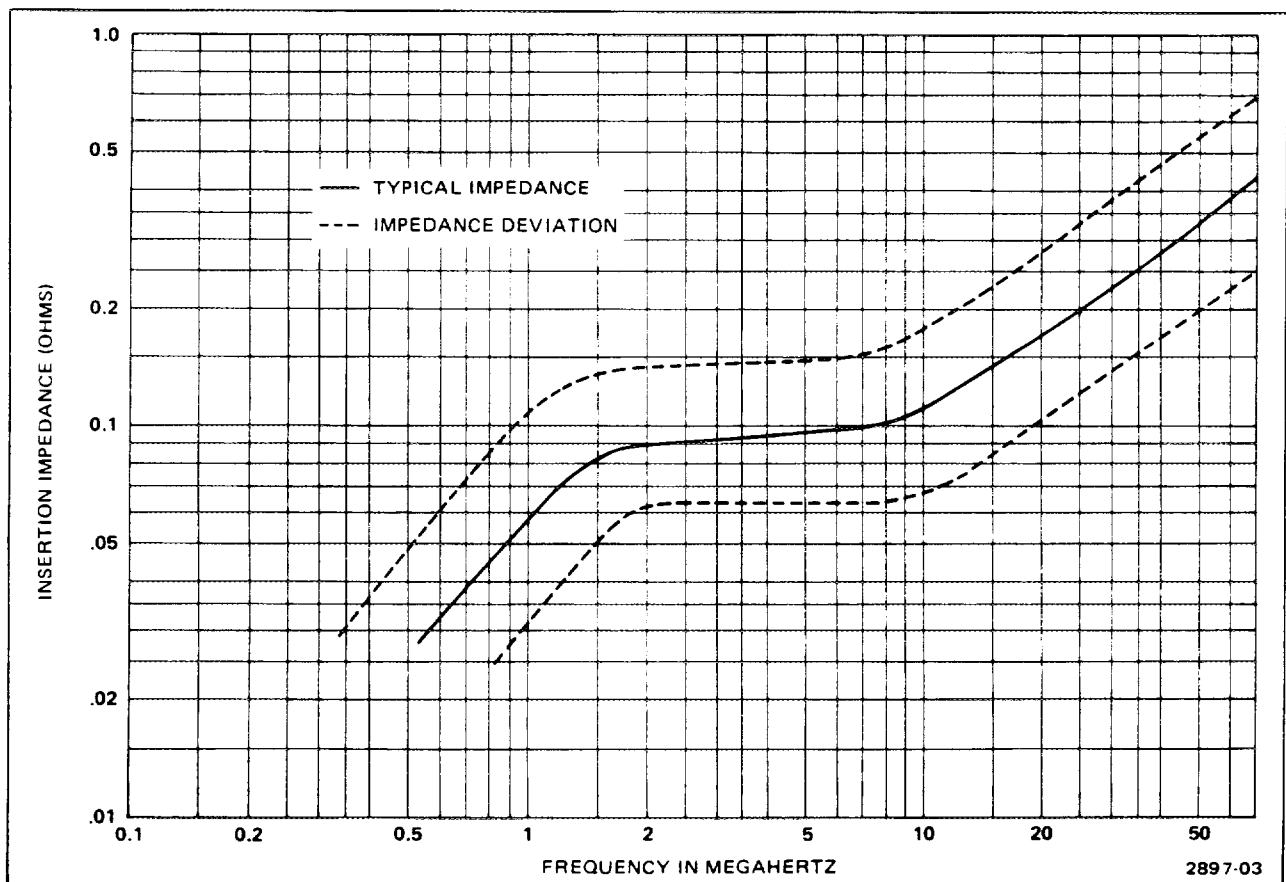

Fig. 2. Insertion impedance versus frequency in megahertz.

OPERATING CONSIDERATIONS

Ground Clip Leads

Two ground-clip leads are supplied with each probe. These leads are provided to ground the probe shield at the probe head to reduce high-frequency electrostatic voltages that could be coupled to the current transformer. Normally, the ground lead is not used in the 1, 2, and 10 mA sensitivities of the current probe amplifier due to undesirable currents that may appear in these more sensitive positions. When observing high-frequency signals, use the short ground lead.

Circuit Loading

To minimize loading of critical circuits, clamp the probe at the low or ground end of a component lead whenever possible.

conductor. Keep this in mind when reading dc current in ferrous leads (such as transistor leads) that may be magnetized. This lead flux causes erroneous readings in the more sensitive current probe amplifier settings.

Direction of Current Flow

To display correct polarity, the probe should be clamped around a conductor with the probe arrow pointing in the direction of conventional current flow (positive to negative).

NOTE

The P6302 Current Probe measures magnetic flux around a conductor, caused by current in the

CAUTION

Do not let the probe transformer core touch the base conductor being tested. The core is not insulated.

MAINTENANCE

CLEANING

Dirt that accumulates on the probe head can be removed with a soft cloth dampened in a mild detergent and water solution. Abrasive cleaners should not be used.

CAUTION

Avoid the use of chemical cleaning agents which might damage the plastics used in this instrument. In particular, avoid chemicals which contain benzene, toluene, xylene, acetone, or similar solvents.

Recommended cleaning agents are isopropyl alcohol (Isopropanol) or ethyl alcohol (Fotocal or Ethanol).

The P6302 Current Probe is designed to withstand normal operation and handling. However, if the probe fails or breaks, replacement parts are available.

Obtaining Replacement Parts

Most electrical and mechanical parts can be obtained through your local Tektronix field office or representative. However, you should be able to obtain many of the standard electronic components from a local commercial source in your area. Before you purchase or order a part from a source other than Tektronix Inc., please check the Replaceable Electrical Parts list for the proper value, rating, tolerance, and description.

SERVICING

The following servicing instructions are for use by qualified personnel only. To avoid personal injury, do not perform any servicing other than that contained in operating instructions unless you are qualified to do so.

Lubrication

Do not lubricate the gap between the stationary and movable transformer core pieces. Any lubricant between the core pieces should be removed with a recommended cleaning agent.

Slide Switch

This switch is lubricated before leaving the factory. Should the switch become noisy, clean and lubricate with switch cleaning lubricant.

Movable Plastic Parts

Should the plastic slide assembly require lubrication, apply silicone-based grease sparingly to the plastic.

Probe Disassembly Procedure (see Fig. 3)

1. Move the probe slider assembly to the OPEN position.
2. Remove the two screws from the bottom of the probe body and pull the strain relief boot back on the cable.
3. While holding the probe in a horizontal position with the slide assembly up, lift the top half of the body and slide the top half off the end of the probe.

NOTE

Don't let the metal ball, in the top of the slide assembly, fall out. The ball may be easily lost.

4. Remove the metal ball.
5. Lift the spring retainer and spring out of the spring holder. Remove the spring and retainer (lift the back of the slide assembly).
6. Lay the probe on its side and remove the slide assembly. When removing the movable portion of the transformer core and the contact for the slide assembly, note the position of the contact spring. Switch contacts are not removable from the slide assembly.
7. Remove the spring holder from the bottom half of the probe body.
8. To remove the stationary transformer core, first lift out the transformer-circuit board assembly, then carefully grip the stationary transformer core and pull it out of its socket. If necessary, unsolder the cable connection to the bottom half of the probe body.

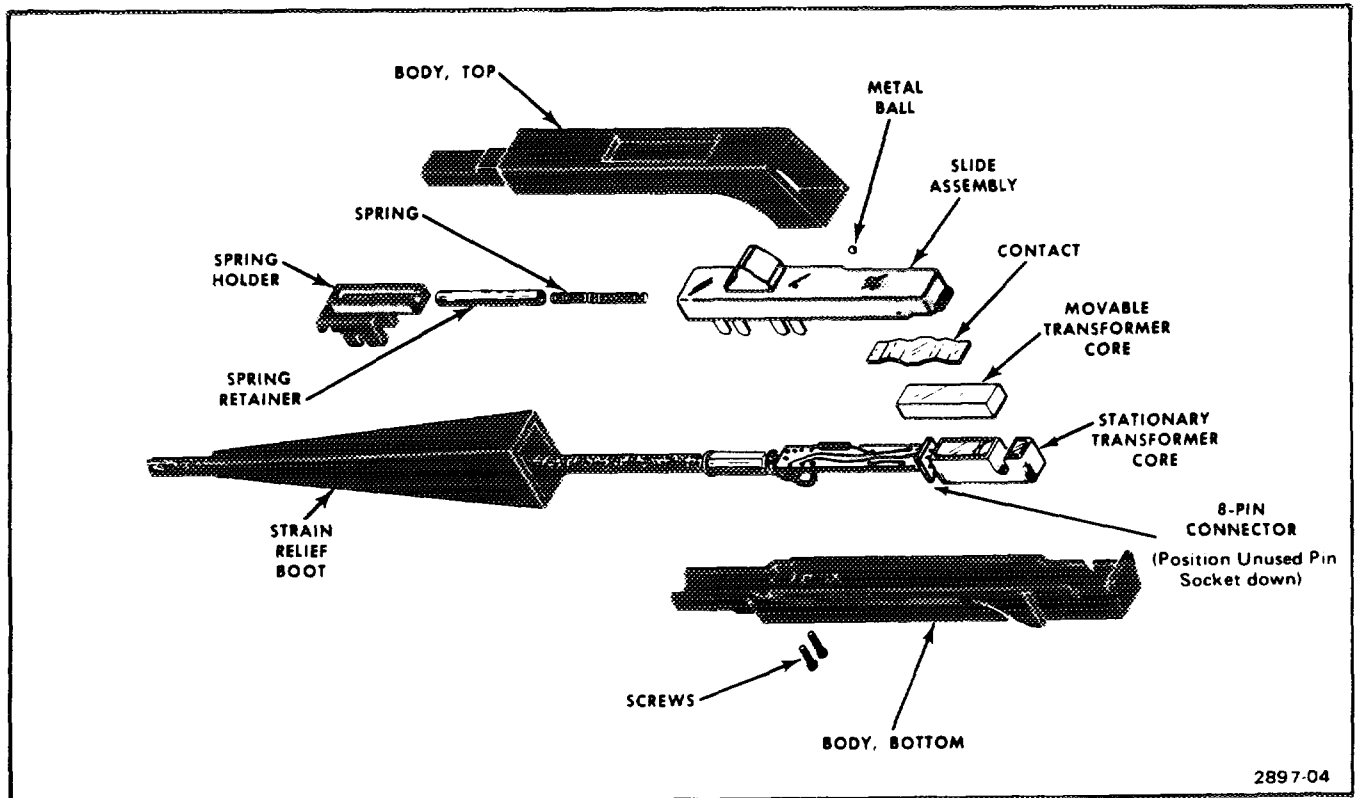

Fig. 3. Probe assembly exploded view.

P6302 Current Probe

Probe Assembly Procedure (see Fig. 3)

1. If unsoldered, resolder the cable connections (2) to the bottom half of the probe body.
2. Plug the stationary transformer core into the seven-pin connector.
3. Place the circuit board and transformer core into the bottom half of the probe body and replace the spring holder.
4. Replace the contact spring and movable core in the slide assembly. Place the spring and spring retainer in the spring guide on the slide assembly.
5. With both halves of the probe body held upside down, insert the slide assembly tip into the slot at the front

of the probe body and bring the two pieces together. Be sure that the slide assembly switch contacts go on the inside (toward the center) of the stationary contacts. As the two pieces are brought together, push the spring retainer into the spring holder.

6. Hold the probe with the slide assembly up and place the metal ball into the hole in the slide assembly.

7. Replace the top half of the probe body, the strain relief boot, and the two screws.

8. The transformer assembly, when ordered, comes with an offset resistor (R18). The polarity marking (+ or -) on the tape attached to the transformer indicates which Hall Bias resistor it will be tied to (R16 is +, R17 is -).

PERFORMANCE CHECK

Introduction

This procedure checks the electrical characteristics that appear in the Specification section of this manual. If the instrument fails to meet the requirements given in this performance check, a maintenance procedure should be performed. This procedure can also be used by an incoming inspection facility to determine acceptability of performance.

The electrical characteristics are valid only if the current probe amplifier is calibrated at an ambient temperature of +20°C to +30°C and operated at an ambient temperature of 0°C to +50°C. Forced air circulation is required for ambient temperature above +40°C.

Tolerances that are specified in this performance check procedure apply to the instrument under test and do not include test equipment error.

Test Equipment Required

The following test equipment, or equivalent, is required to perform the performance check. Test equipment characteristics listed are the minimum required to verify the performance of the equipment under test. Substitute equipment must meet or exceed the stated requirements. All test equipment is assumed to be operating within tolerances.

Special test devices are used where necessary to facilitate the procedure. Most of these are available from Tektronix, Inc. and can be ordered through your local Tektronix Field Office or representative.

P6302 Current Probe

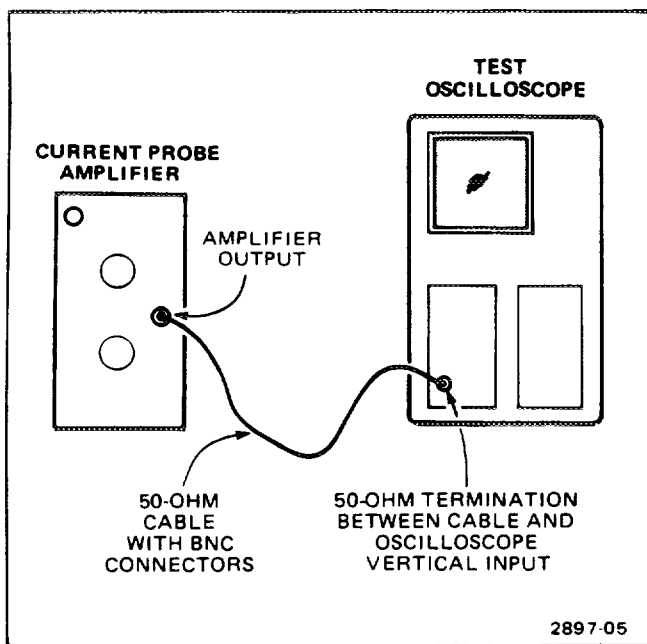

Fig. 4. Setup for preliminary procedure.

5. Set test oscilloscope vertical sensitivity for 10 mV/div.

6. With the test oscilloscope input coupling switch at ground, position the trace vertically to graticule center. Switch input coupling to dc.

7. Set the current probe amplifier function to adjust the dc level for zero output (trace centered on the test oscilloscope graticule).

8. Set amplifier sensitivity for 1 mA/div.

9. Momentarily apply degaussing voltage to the probe.

10. Set current probe amplifier coupling to dc.

11. Set dc balance for zero output (trace centered on test oscilloscope graticule).

Risetime Check

See Fig. 5 for test setup.

Set Controls:

Current Probe Amplifier

Bandwidth	100 MHz
Current/Div	2 mA

Calibration Generator

Period	1 μ s
--------	-----------

Test Oscilloscope

Volts/Div	10 mV
Input Coupling	dc
Time/Div	20 ns

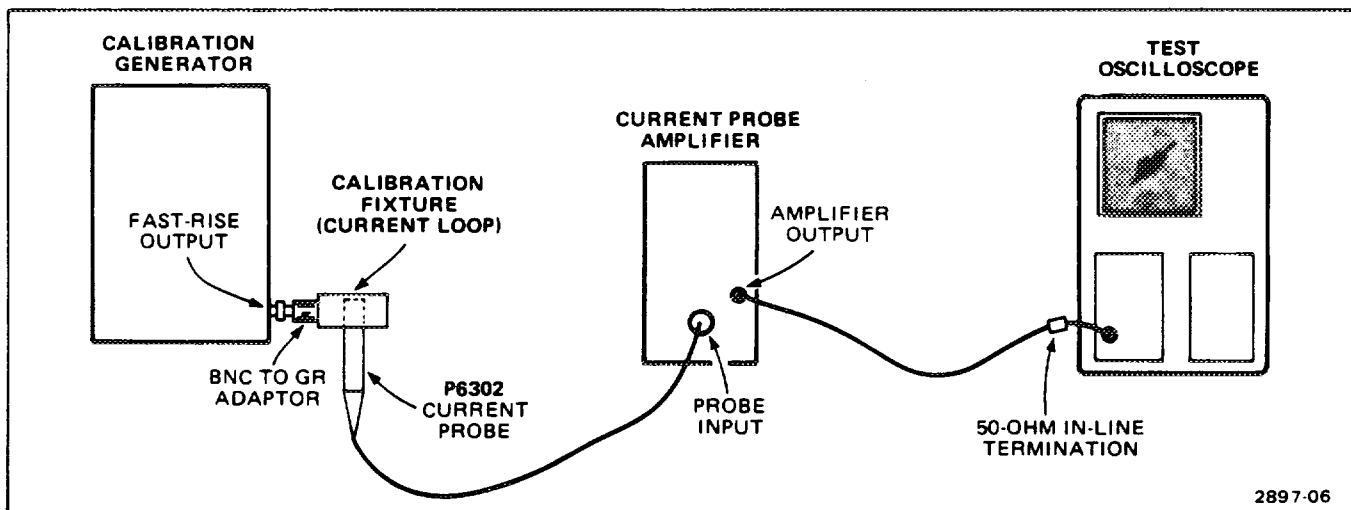

Fig. 5. Test setup for risetime check.

Table 4
TEST EQUIPMENT REQUIRED

Description	Minimum Specification	Usage	Examples
1. Test Oscilloscope	Bandwidth, to 150 MHz; vertical deflection, 5 mV/Div; time/div, 2 ms.	All measurements	TEKTRONIX 7704 with 7A16A Amplifier and 7B80 Time Base.
2. Calibration Generator	Fast rise output: period 0.1 ms; duty cycle, approx. 50%; amplitude, 200 mV p-p, into 50 ohms.	Risetime measurement.	TEKTRONIX PG 506 ³ Pulse Generator.
3. Constant Amplitude Sine Wave Generator	Frequency range, to at least 50 MHz with 50 kHz reference frequency; amplitude range, to 4 V p-p; impedance, 50 Ω ; amplitude accuracy (50 kHz reference), within 3% of indicated amplitude on 5 V range, into 1% termination; flatness, output amplitude does not vary more than 3% from actual amplitude of 50 kHz reference, to 50 MHz.	Bandwidth checks.	TEKTRONIX SG 503 ³ Leveled Sine Wave Generator.
4. Current Probe Amplifier	Bandwidth, 100 MHz; current/div accuracy, within 3%.	All measurements.	TEKTRONIX AM 503 ³ current probe amplifier.
5. Cable	Impedance, 50 Ω ; length, 42 inches; connectors, bnc.	Amplifier output to test oscilloscope.	Tektronix Part No. 012-0057-01.
6. Termination	Impedance, 50 Ω ; connector, bnc.	Amplifier output to test oscilloscope.	Tektronix Part No. 011-0049-01.
7. 10X Attenuator (2 required)	Attenuation accuracy, $\pm 2\%$.	Noise check.	Tektronix Part No. 011-0059-02.
8. Calibration Fixture (Current Loop)	Impedance, 50 Ω .	Bandwidth, risetime, aberrations.	Tektronix Part No. 067-0559-00.

³ Requires TM 500-Series Power Module.

Preliminary Procedure

1. Ensure that all power switches are off.

2. Ensure that all test equipment and the power module into which the current probe amplifier will be installed are suitably adapted to the line voltage to be applied.

3. Install the current probe amplifier into the power module and connect the P6302 current probe. Install all other applicable TM 500-Series test equipment into the power module.

4. Connect the power module(s) and test equipment to a suitable line voltage source. Turn all equipment on and allow at least 20 minutes for the equipment to warm up and stabilize.

NOTE

All steps in the Performance Check require the following setup. (See Fig. 4.) With each of the more complex steps, an equipment setup illustration is provided. Titles for front panel controls and connectors are initial capitals in this procedure (e.g., Current/Div, Balance, etc.).

a. Adjust Calibration Generator output for five-division vertical display on test oscilloscope.

b. Switch test oscilloscope Time/Div to 2 ns.

c. Measure risetime between 10 and 90% amplitude points.

d. CHECK—for 7 ns, maximum risetime.

Set Controls:

Current Probe Amplifier

Bandwidth	100 MHz
Current/Div	5 mA

a. Set Calibration Generator for 2 volt p-p output.

b. Adjust test oscilloscope vertical sensitivity for a six-division display (uncalibrated).

c. CHECK—display flat within 3% on test oscilloscope.

Aberrations Check

See Fig. 6 for test setup.

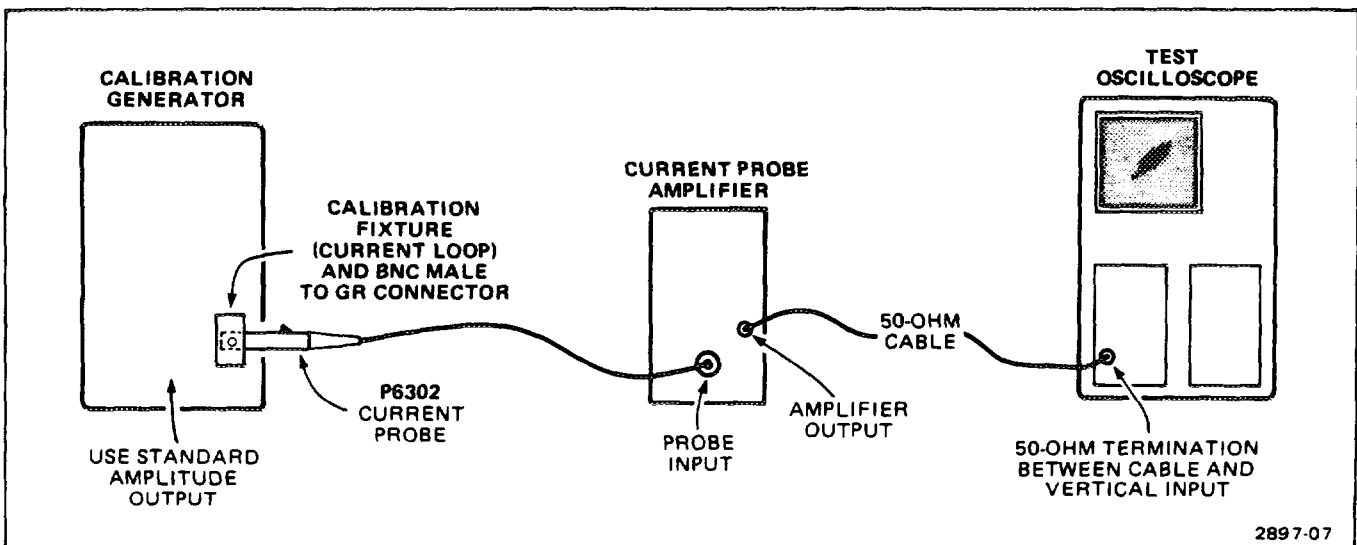

Fig. 6. Test setup for aberrations check.

P6302 Current Probe

Noise Check

See Fig. 7 for test setup.

Set Controls:

Current Probe Amplifier

Current/Div 1 mA
 Bandwidth 5 MHz

Test Oscilloscope

• Time/Div 100 μ s
 • Volts/Div 10 mV

Calibration Generator

Frequency 1 kHz
 Function Square wave

a. Adjust Calibration Generator Amplitude until two free-running traces just merge (no dark area between traces). See Fig. 8.

b. Remove one 10X attenuator.

c. Measure the display amplitude on the test oscilloscope. Divide display amplitude by 10.

Example: two divisions of display at 10 mV/Div = 20 mV (equivalent to 2 mA), divided by 10 = 0.2 mA of noise, measured tangentially.

d. CHECK—for 0.3 mA maximum noise, measured tangentially.

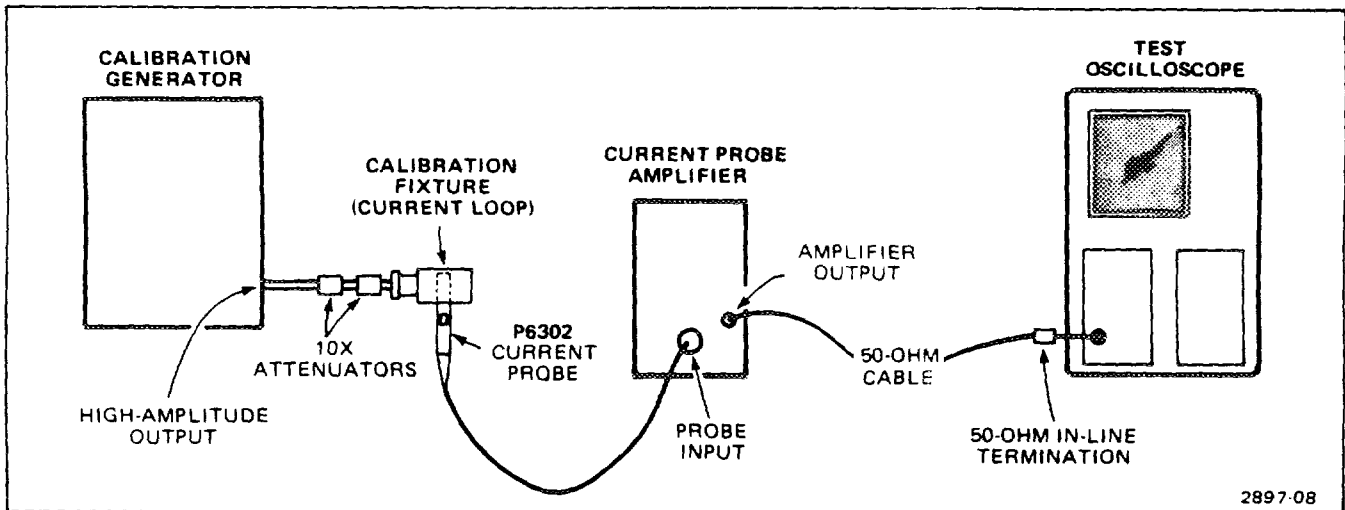

Fig. 7. Test setup for noise check.

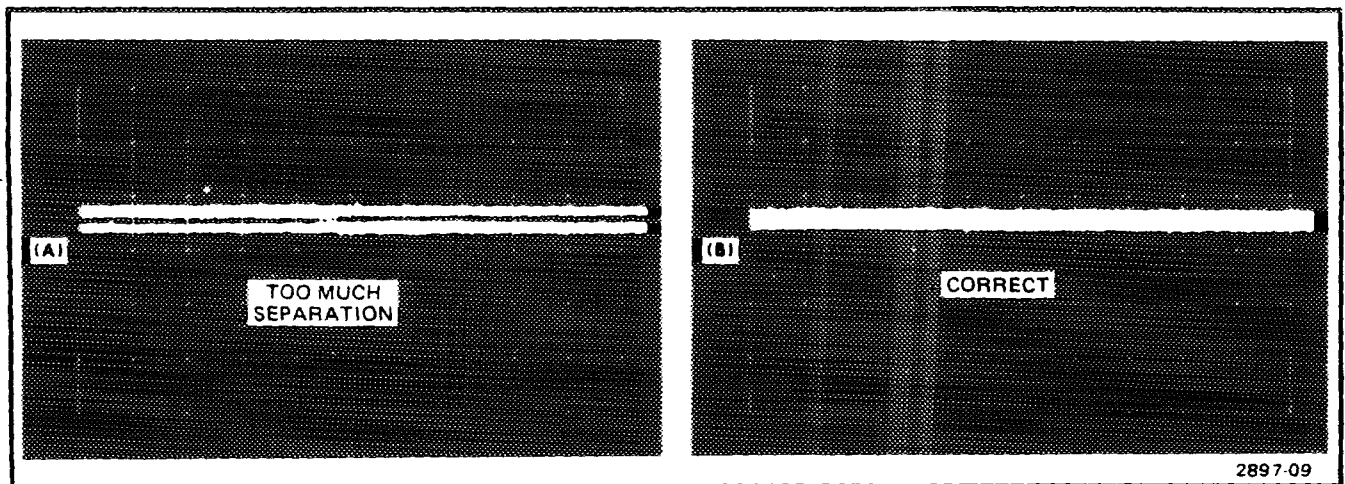

Fig. 8. Display of tangentially-measured noise (A) incorrect; dark area showing between traces. (B) correct display.

Bandwidth Check

See Fig. 9 for test setup.

Set Controls:

Current Probe Amplifier

Bandwidth 100 MHz
 Current/Div 5 mA

Test Oscilloscope

Volts/Div 10 mV

Sine Wave Generator

Frequency 50 kHz reference

a. Set Constant Amplitude Sine-Wave Generator amplitude for six-division display on test oscilloscope.

b. Increase Constant Amplitude Sine-Wave Generator frequency until test oscilloscope vertical display amplitude decreases to 4.2 divisions.

c. CHECK—that Constant Amplitude Sine-Wave Generator frequency is 50 MHz or greater.

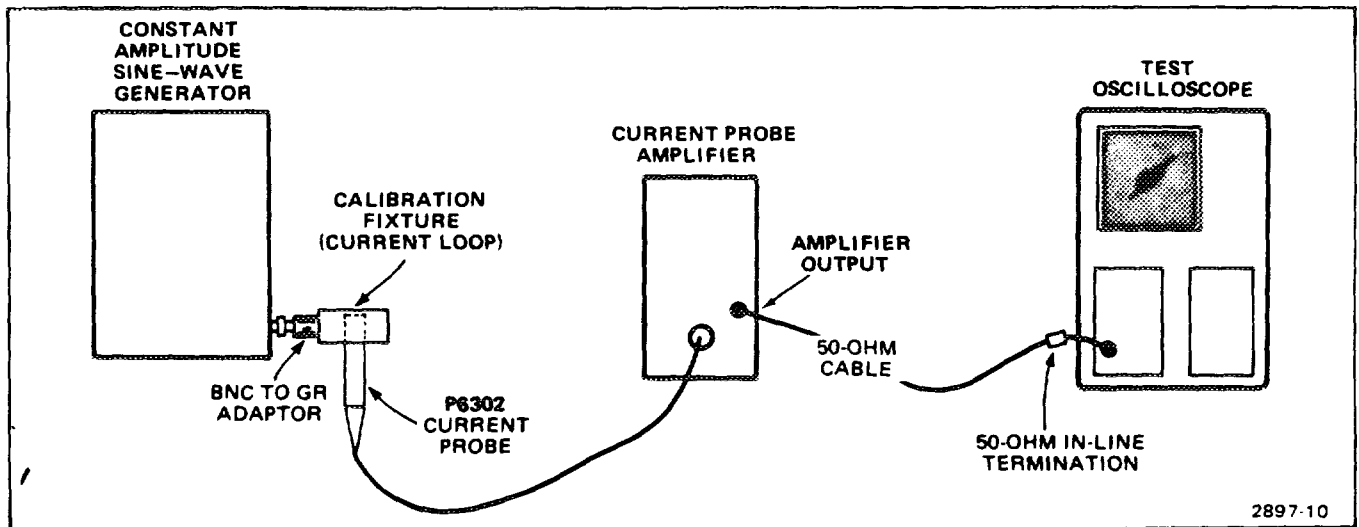

Fig. 9. Test setup for bandwidth check.

REPLACEABLE PARTS

PARTS ORDERING INFORMATION

Replacement parts are available from or through your local Tektronix, Inc. Field Office or representative.

Changes to Tektronix instruments are sometimes made to accommodate improved components as they become available, and to give you the benefit of the latest circuit improvements developed in our engineering department. It is therefore important, when ordering parts, to include the following information in your order: Part number, instrument type or number, serial number, and modification number if applicable.

If a part you have ordered has been replaced with a new or improved part, your local Tektronix, Inc. Field Office or representative will contact you concerning any change in part number.

Change information, if any, is located at the rear of this manual.

SPECIAL NOTES AND SYMBOLS

X000 Part first added at this serial number
00X Part removed after this serial number

ITEM NAME

In the Parts List, an Item Name is separated from the description by a colon (:). Because of space limitations, an Item Name may sometimes appear as incomplete. For further Item Name identification, the U.S. Federal Cataloging Handbook H6-1 can be utilized where possible.

ABBREVIATIONS

ACTR	ACTUATOR	PLSTC	PLASTIC
ASSY	ASSEMBLY	QTZ	QUARTZ
CAP	CAPACITOR	RECP	RECEPTACLE
CER	CERAMIC	RES	RESISTOR
CKT	CIRCUIT	RF	RADIO FREQUENCY
COMP	COMPOSITION	SEL	SELECTED
CONN	CONNECTOR	SEMICOND	SEMICONDUCTOR
ELCTLT	ELECTROLYTIC	SENS	SENSITIVE
ELEC	ELECTRICAL	VAR	VARIABLE
INCAND	INCANDESCENT	WW	WIREWOUND
LED	LIGHT EMITTING DIODE	XFMR	TRANSFORMER
NONWIR	NON WIREWOUND	XTAL	CRYSTAL

REPLACEABLE ELECTRICAL PARTS

Ckt No.	Tektronix Part No.	Serial/Model No. Eff	Dscont	Name & Description	Mfr Code	Mfr Part Number
A1	670-4647-00			CKT BOARD ASSY: PROBE	80009	670-4647-00
LR15	108-0330-00			COIL, RF: 0.4UH	80009	108-0330-00
R14	317-0101-00			RES., FXD, CMPSN: 100 OHM, 5%, 0.125W	01121	BB1015
R16	317-0270-00			RES., FXD, CMPSN: 27 OHM, 5%, 0.125W	01121	BB2705
R17	317-0220-00			RES., FXD, CMPSN: 22 OHM, 5%, 0.125W	01121	BB2205
R18	SELECTED					
T15	120-0741-00			XFMR, TOROID: 8 TURNS	80009	120-0741-00

REPLACEABLE MECHANICAL PARTS

Fig. & Index No	Tektronix Part No	Serial/Model No. Eff	Dscont	Qty	1 2 3 4 5	Name & Description	Mfr Code	Mfr Part Number
1-	010-6302-01			1		LEAD, TEST: 20 AMP, 2 METER L, W/ACCESS	80009	010-6302-01
	010-6302-00			1		LEAD, TEST: 20 AMP, 2 METER L	80009	010-6302-00
-1	204-0288-00			1		BODY HALF, PROBE: TOP (ATTACHING PARTS)	80009	204-0288-00
-2	213-0087-00			2		SCR, TPG, THD CTG: 2-32 X 0.300 L, PNH STL	83385	OBD
-3	214-0997-00			1		BALL BEARING: 0.094 OD, SST	27545	OBD
-4	214-0849-00			1		RTR, RTN SPR: 0.132 ID X 0.160 OD X 1.77 L	80009	214-0849-00
-5	214-0835-00			1		SPRING, HLCPS: 0.12 OD X 2.625 L	80009	214-0835-00
-6	351-0121-00			1		CONT ASSY, ELEC: PROBE SLIDE ASSY	80009	351-0121-00
-7	214-0854-00			1		CONTACT, ELEC: 0.340 W X 1.00 L	80009	214-0854-00
-8	120-0464-02			1		TRANSFORMER, CUR: UPPER AND LOWER	80009	120-0464-02
-9	352-0106-00			1		HOLDER, SPR RTR: BLACK, ACETAL RESIN	80009	352-0106-00
	175-1836-01			1		CA ASSY, SP, ELEC: W/CIRCUIT CARD	80009	175-1836-01
-10	-----			1		CKT BOARD ASSY: PROBE (SEE A1 EPL)		
-11	136-0252-00			7		SOCKET, PIN TERM: 0.145 INCH LONG	00779	2-330808-7
-12	352-0287-00			1		HOLDER, CKT CARD:	80009	352-0287-00
-13	175-1836-00			1		CA ASSY, SP, ELEC: 6.30 AWG/2.50OHM COAX, P	80009	175-1836-00
-14	204-0714-00			1		BODY HALF, PROBE: W/CONTACTS AND GROUND, BOT	80009	204-0714-00
						STANDARD ACCESSORIES		
	070-2897-00			1		SHEET, TECHNICAL: INSTR, P6302	80009	070-2897-00

CROSS INDEX—MFR. CODE NUMBER TO MANUFACTURER

Mfr. Code	Manufacturer	Address	City. State. Zip
00779	AMP, INC.	P O BOX 3608	HARRISBURG, PA 17105
01121	ALLEN-BRADLEY COMPANY	1201 2ND STREET SOUTH	MILWAUKEE, WI 53204
27545	HARTFORD-UNIVERSAL CO.	951 WEST STREET	ROCKY HILL, CT 06067
80009	TEKTRONIX, INC.	P O BOX 500	BEAVERTON, OR 97077
83385	CENTRAL SCREW CO.	2530 CRESCENT DR.	BROADVIEW, IL 60153

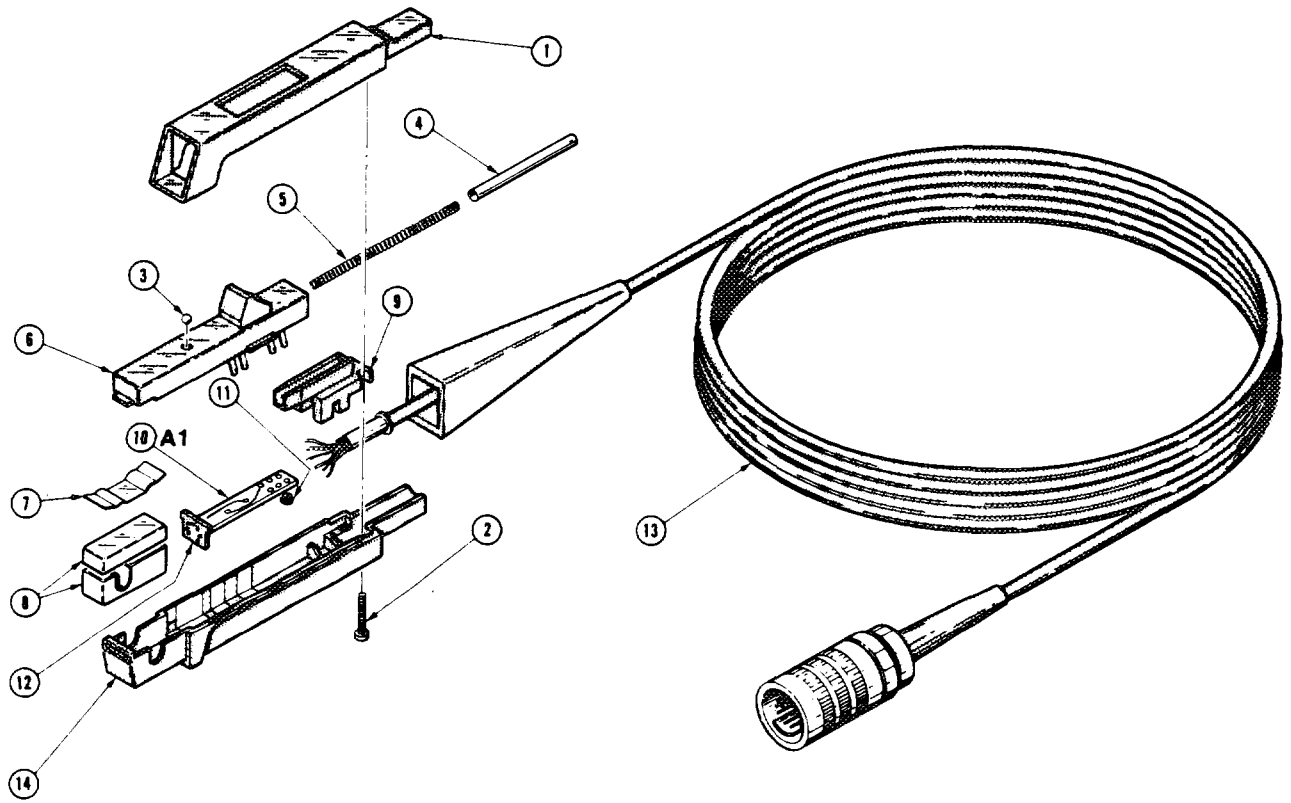

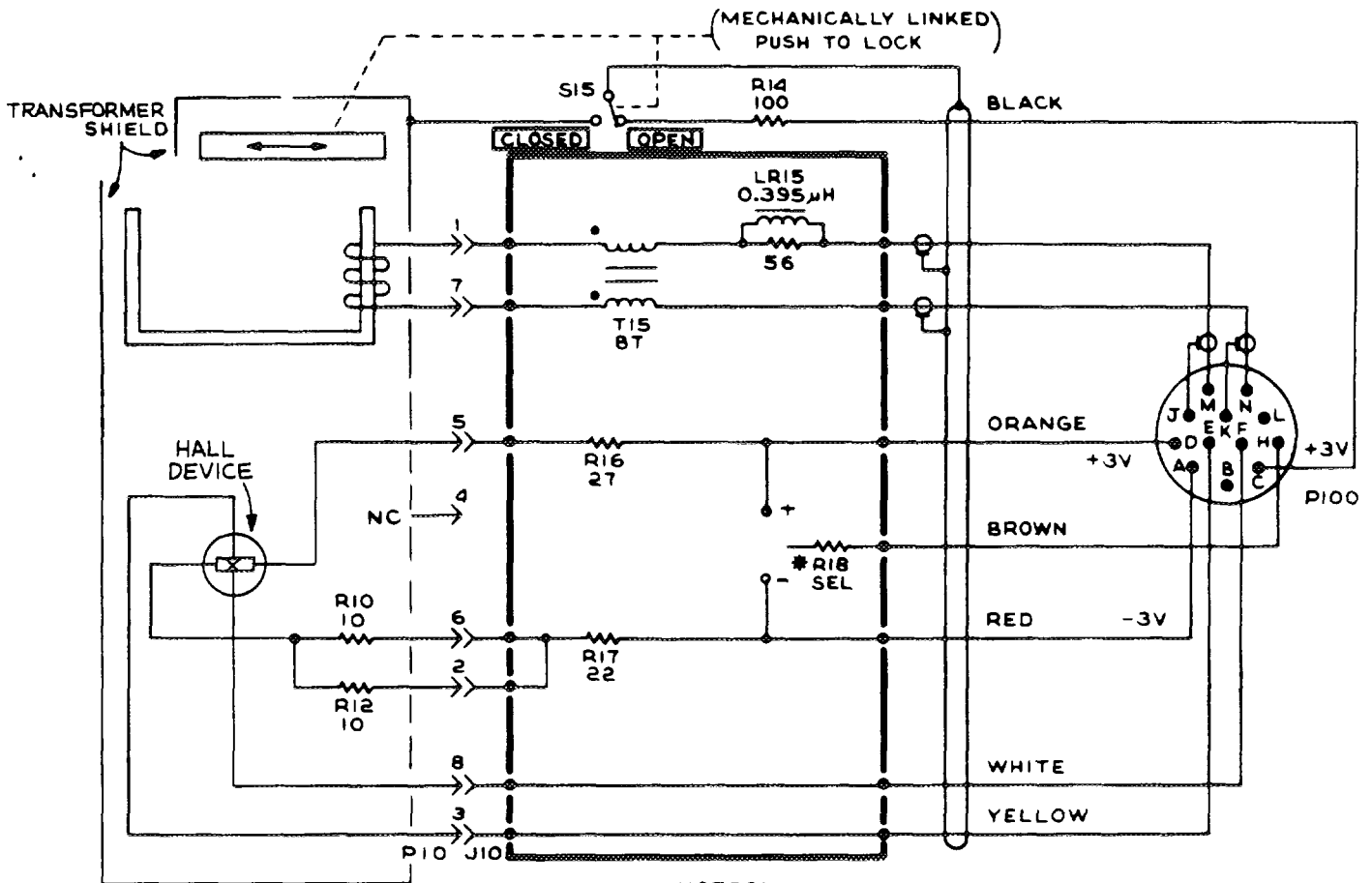

NOTES:

1. * R18 IS CONNECTED EITHER TO THE ORANGE OR RED LEAD.
2. P10 IS COUNTED IN A CW DIRECTION STARTING AT THE KEY.

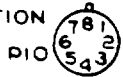

P6302

@
2897-13

PROBE

P6302

2897-11



BLOCK DIAGRAM

